

REVISIONS			
REV.	DESCRIPTION	DATE	APPRVD.

- Notes:**
1. NRCR features a built in recirculation pump and check valve. For the recirculation pipe loop, do not exceed maximum pipe equivalent length:
 1/2" pipe - 200 ft.
 3/4" pipe - 500 ft.
 2. Quick Connect Cable is only available for 2 unit Multi-System. Must be same models.
 3. This unit produces acidic condensate during operation and must be drained and disposed according to local code. Use pipe material that will not corrode such as PVC or CPVC. Do not use materials such as black steel, iron, or other metals. Slope horizontal pipe downwards 1/4" per foot towards drain or condensate pump. Do not submerge or block end of drain pipe.

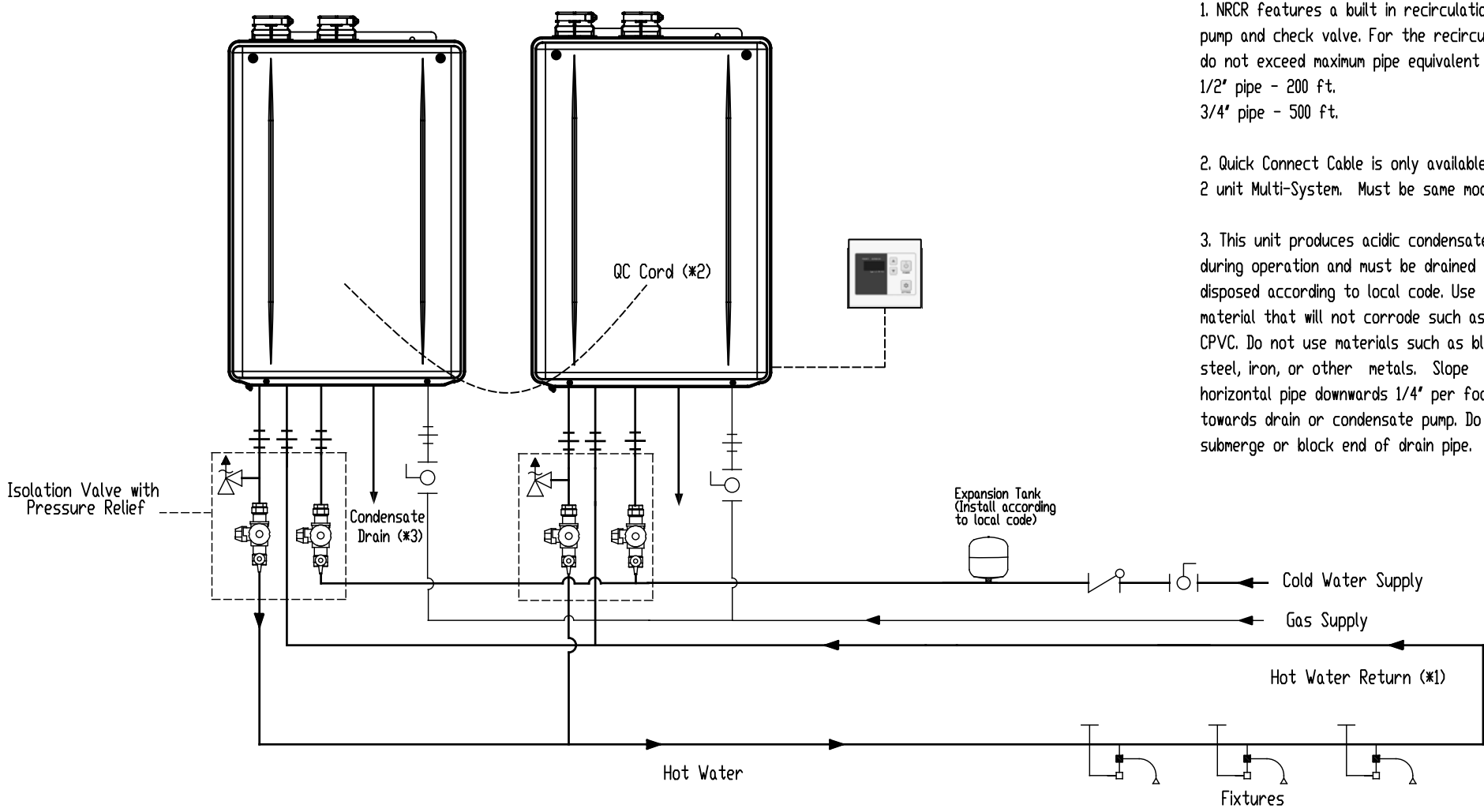

NORITZ
 11160 Grace Avenue
 Fountain Valley, California 92708
 866-7NORITZ (866-766-7489)
 www.noritz.com

MODEL: Residential Condensing-NRCR
 APPLICATION: Domestic Hot Water Quick Connect System Recirculation
 DRAWING NUMBER: NRCR-REC-QC
 DRAWING DATE: April 2020

Noritz Accessories

- Isolation Valve with Pressure Relief
- Residential Neutralizer
- Quick Connect Cable, for 2 unit Multi-System
- On-Demand Switch (1. # IHK-GB) (2. # IHK-RS)

Note: This diagram is for reference only. Installation must comply with State and Local Code, all gas and water pipe must be sized correctly to specific length, according to accepted engineering methods or the UPC Code for Noritz Water Heaters to operate correctly.

	Shut-off Ball Valve		Aquastat (Honeywell Model #L6006A or L6006C)
	Check Valve		Pump
	Union		Mixing Valve
	Pressure Relief Valve (Watts 174A, Zurn P3000BR, Cash Acme F-82)		Thermal Expansion Tank