

REVISIONS			
REV.	DESCRIPTION	DATE	APPRVD.

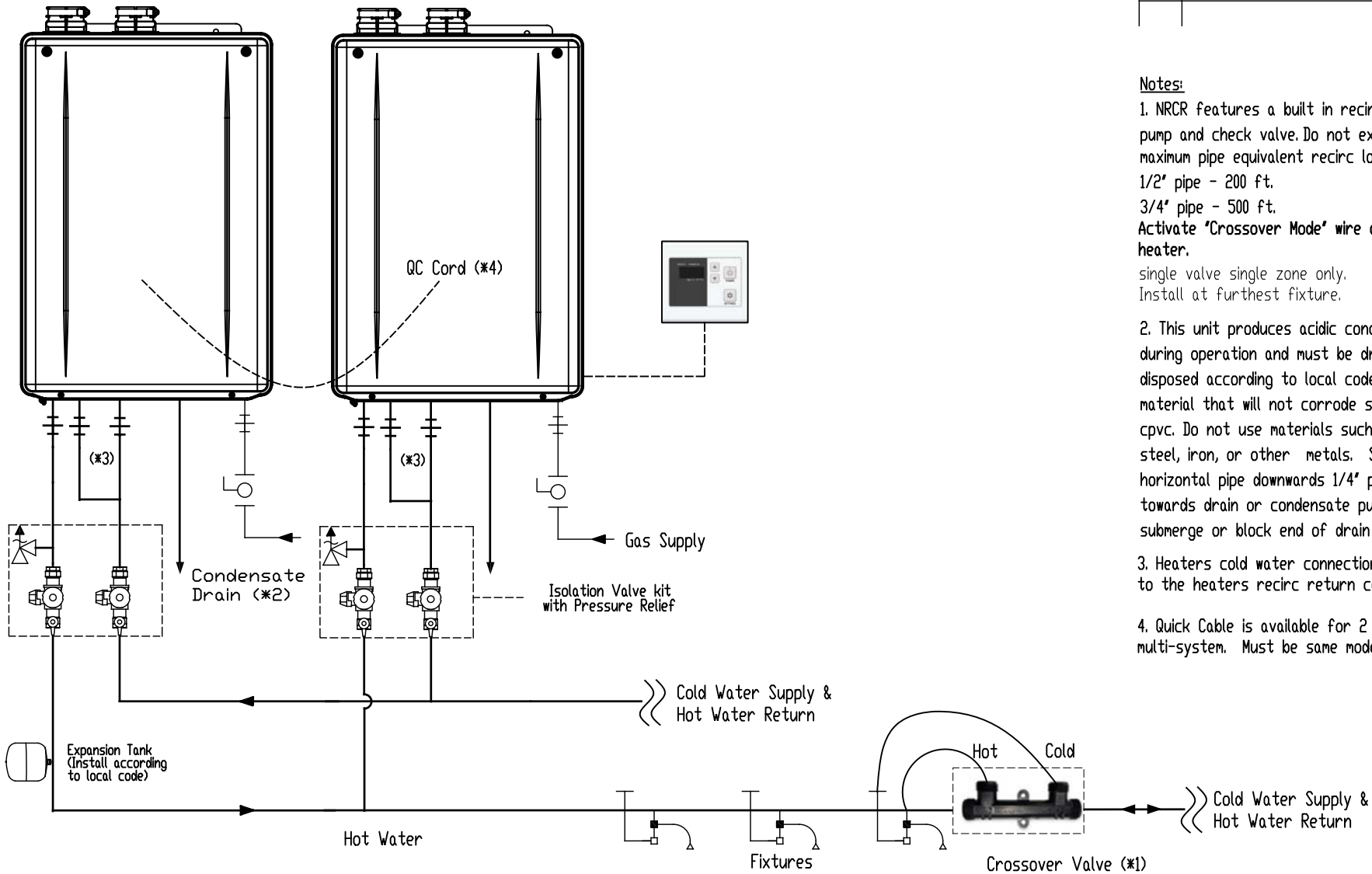





Notes:

1. NRCR features a built in recirculation pump and check valve. Do not exceed maximum pipe equivalent recirc loop length:
 1/2" pipe - 200 ft.
 3/4" pipe - 500 ft.
 Activate "Crossover Mode" wire connector inside heater.
 single valve single zone only.
 Install at furthest fixture.
2. This unit produces acidic condensate during operation and must be drained and disposed according to local code. Use pipe material that will not corrode such as pvc or cpvc. Do not use materials such as black steel, iron, or other metals. Slope horizontal pipe downwards 1/4" per foot towards drain or condensate pump. Do not submerge or block end of drain pipe.
3. Heaters cold water connection must branch to the heaters recirc return connection.
4. Quick Cable is available for 2 unit multi-system. Must be same models



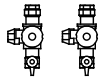

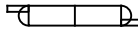



NORITZ
 11160 Grace Avenue
 Fountain Valley, California 92708
 866-7NORITZ (866-766-7489)
 www.noritz.com

MODEL: Residential Condensing-NRCR
 APPLICATION: Domestic Hot Water Recirculation
 DRAWING NUMBER: NRCR-CROSS REC
 DRAWING DATE: April 2020

Noritz Accessories

-  Isolation Valve Kit with Pressure Relief (# IK-WV-200-1-TH/LF)
-  Crossover Valve Kit (# CSV-BPK)
-  Condensate Neutralizer (# NC-1S)
-  On-Demand Switch (1. # IHK-GB) (2. # IHK-RS)

Note: This diagram is for reference only. Installation must comply with State and Local Code, all gas and water pipe must be sized correctly to specific length, according to accepted engineering methods or the UPC Code for Noritz Water Heaters to operate correctly.

-  Shut-off Ball Valve
-  Check Valve
-  Union
-  Pressure Relief Valve (Watts 174A, Zurn P3000BR, Cash Acme F-82)
-  Aquastat (Honeywell Model #L6006A or L6006C)
-  Pump
-  Mixing Valve
-  Thermal Expansion Tank