

System Controller

SC-201-12M, SC-201-24M

Installation Manual

Potential dangers from accidents during installation and use are divided into the following two categories. Closely observe these warnings, they are critical to your safety.



WARNING

Denotes content that may result in fire, serious bodily injury and even death when ignored.



NOTICE

Denotes content that may result in bodily injury and physical damage when ignored.

Requests to Installers





WARNING

In order to use this product safely, read this installation manual carefully and follow the installation instructions.

- Failures and damage caused by erroneous work or work not as instructed in this manual are not covered by the warranty.
- Refer to installation manual attached to the appliance as well.
- Check that installation was done in accordance with this Installation Manual upon completion.
- After completion of installation, be sure to hand this Installation Manual to the customer.

1. Included Accessories

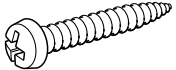
The following accessories are included with this product. Check for missing items before installing.

Part	Shape	Q'ty	Part	Shape	Q'ty
Installation Manual (this document)		1	Tapping Screw		5
Y terminal		15	Remote Controller Cord (10ft)		1

Multi-System Wiring

- The below diagram shows the connection of 3 units to the system controller. When connecting 4 or more units, follow the same procedure.
- Always connect a remote controller to the system controller. Do not connect the included remote controllers to the individual water heaters. These remote controllers will not be used.
- The connection of a recirculation pump, operation relay, or operation switch, as shown in the diagram, are optional.
- When connecting units to the water heater terminals in the system controller, they must be connected in order (1, 2, 3, etc.).

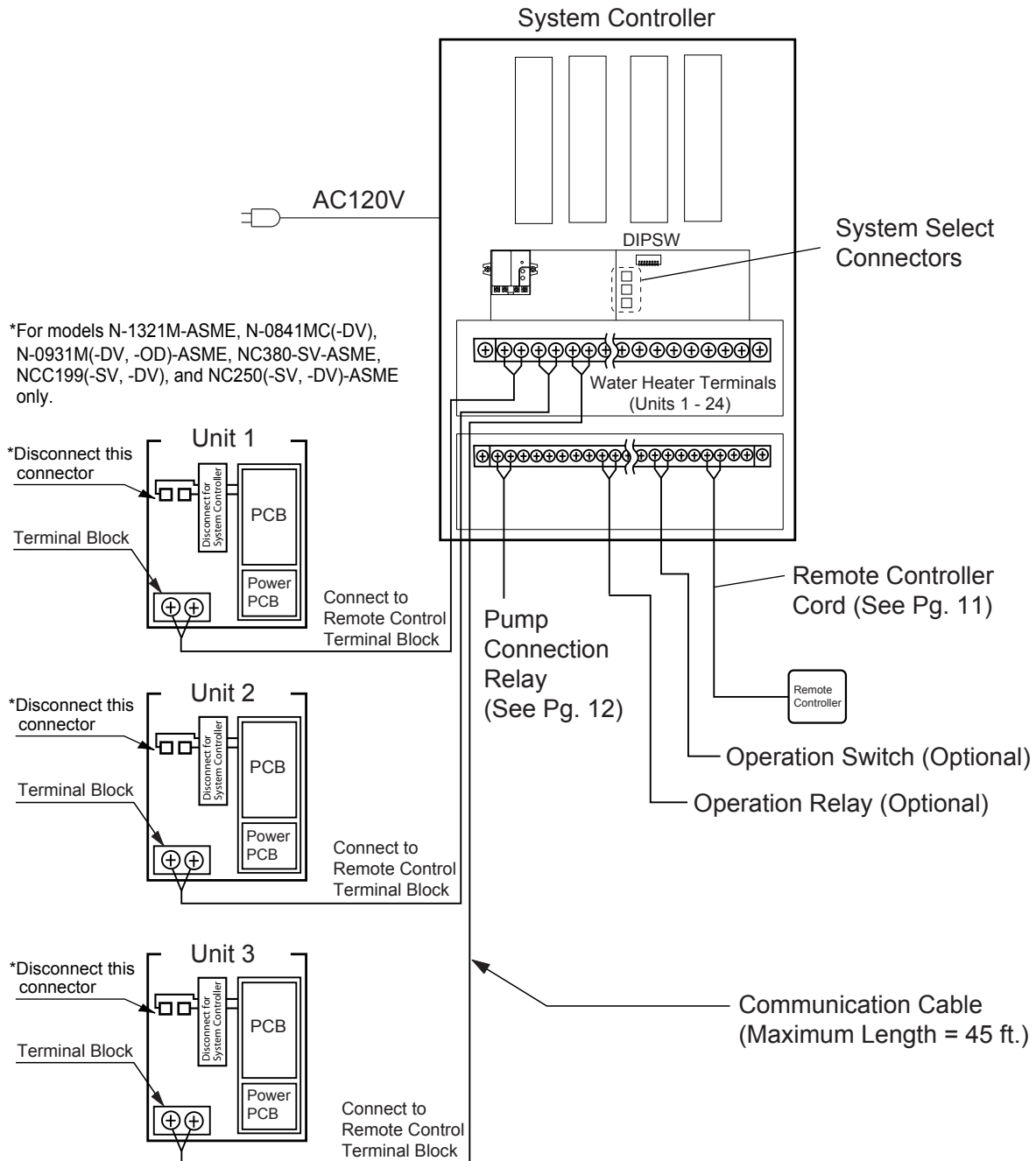

System Select Connectors

If this system will be installed with a recirculation system, a storage tank, or with a filtration system, unplug the connector that corresponds to that type of system.

* If none of these circulating systems are used, do not unplug these connectors.

(1) If the units will be installed in a recirculation system:

Disconnect the top connector referenced below as "Recirculation System" (1).

(2) If the units will be installed with a storage tank:

Disconnect the bottom connector referenced below as "Storage System" (3).

(3) If the units will be installed with a water filtration system:

Disconnect the middle connector referenced below as "Filtration System" (2).

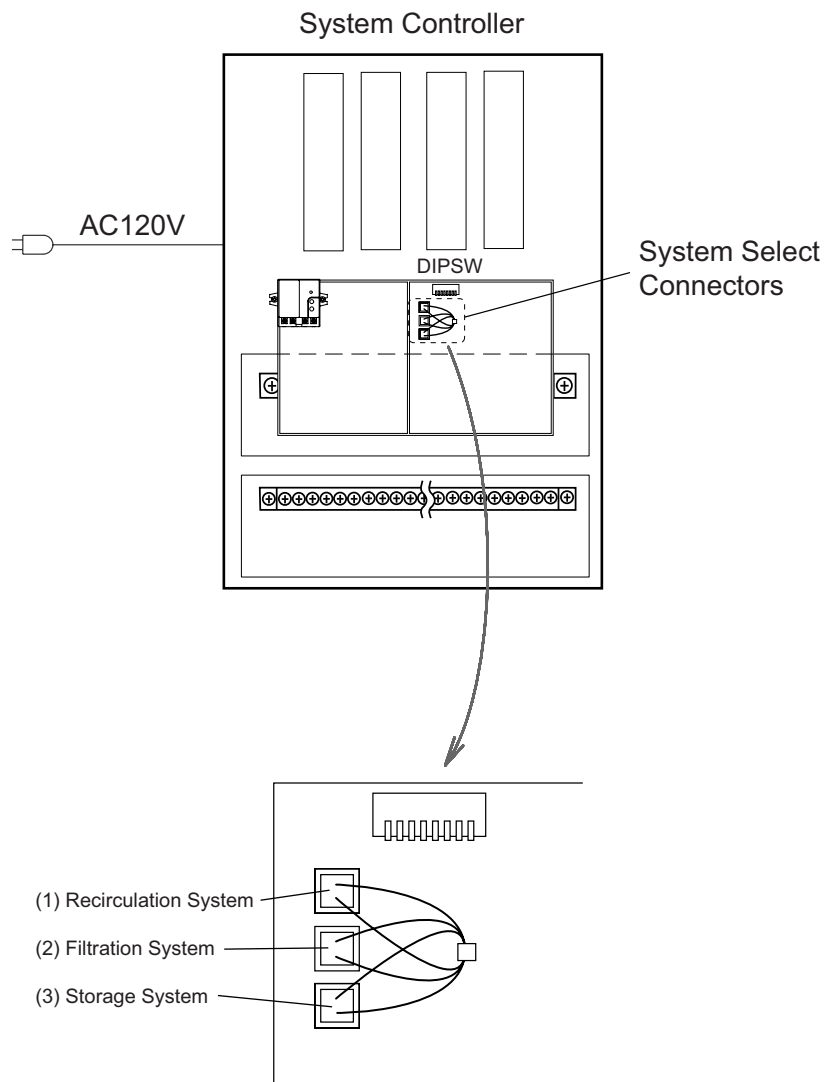

Multi-System

A. Installation without a recirculation system

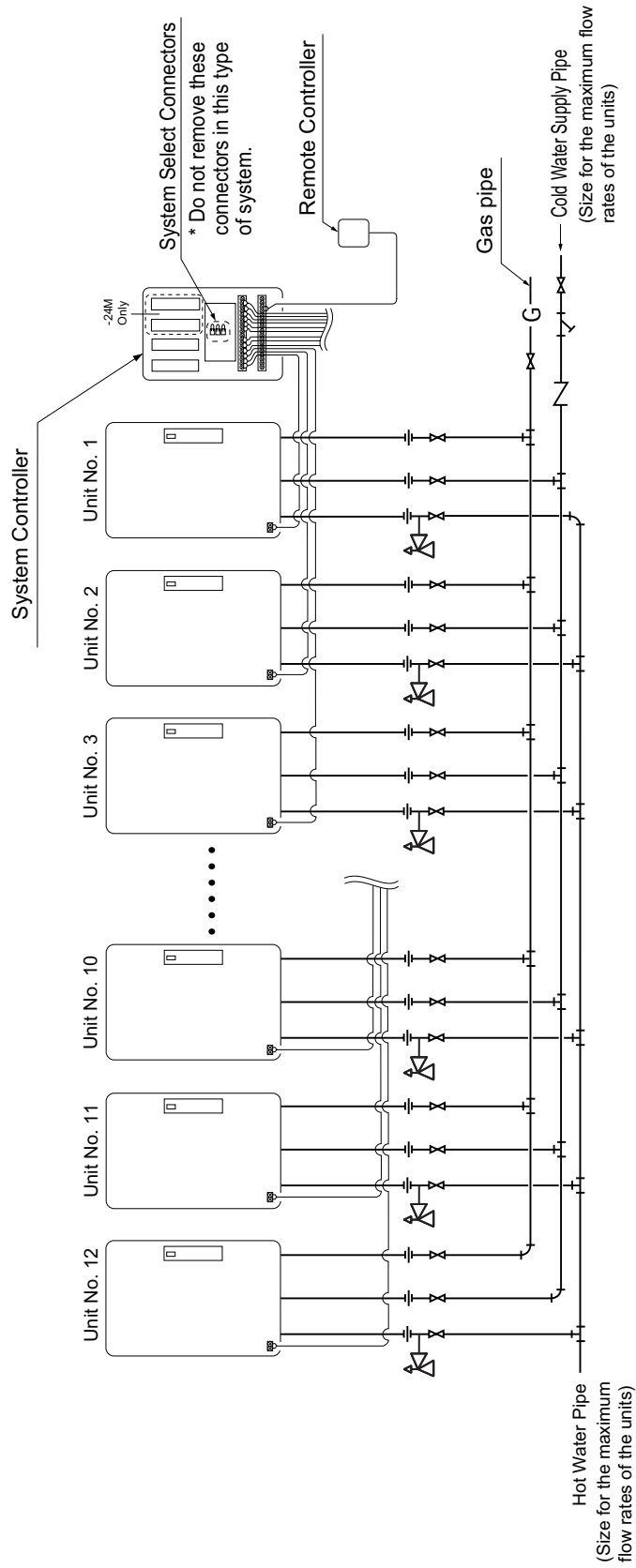

- Insulate or apply heating materials to both the cold water supply piping and the hot water piping to prevent freezing during cold weather and to prevent heat loss through the piping.

B-1. Example of Recirculation with a Multi-System

This system will make hot water more quickly available to remote fixtures.

The pump will circulate water through the loop until the entire loop is warm, and then the system controller will turn off the pump until the loop cools down.

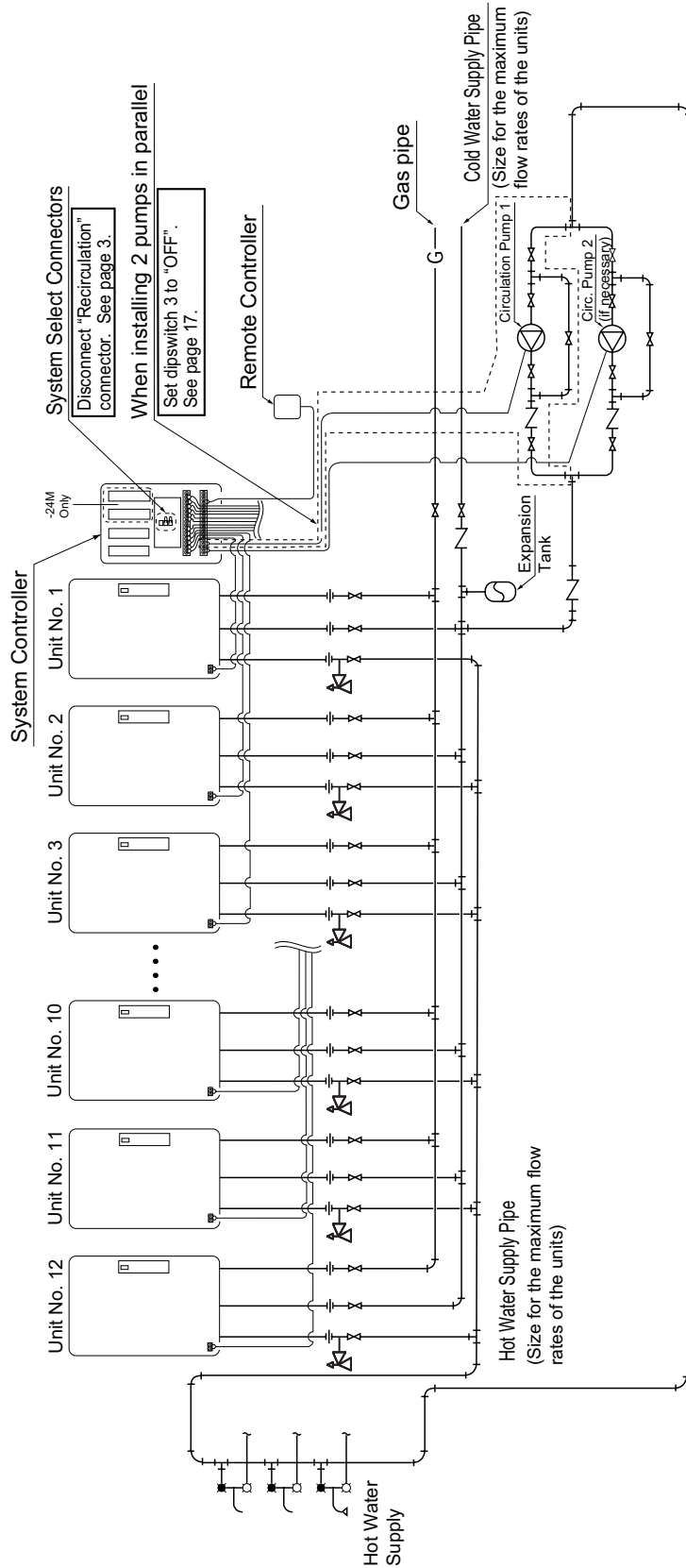

* Size the pump to provide at least 8L/min. (2 GPM) @ 3m (10 feet) of head + piping losses through the system. Check the maintenance monitors on the unit to make sure the pump is providing adequate flow.

• Make sure that the flow rate is not greater than 1.2m/sec. (4 ft./sec.).

(3/4": 20L/min. (5 GPM), 1 1/4": 50L/min. (13 GPM))

If the flow is too low, the recirculation loop temperature will not be warm enough, if the flow is too high, the lifetime of the unit will be reduced.

* If there are multiple circulation loops, try to make the flow rate 3 - 5L/min. (.75 - 1.25 GPM) in each loop.

* Use copper or stainless water piping for the entire system.

B-2. Example of Installation with a Storage Tank and Recirculation System

The pump will push water through the Multi-System to heat up the tank.

When the return temperature is high, the flow within the device will be limited to 10L/min. (2.5 GPM)*. (For the N-084M, the flow will be limited to 1.25 GPM.)

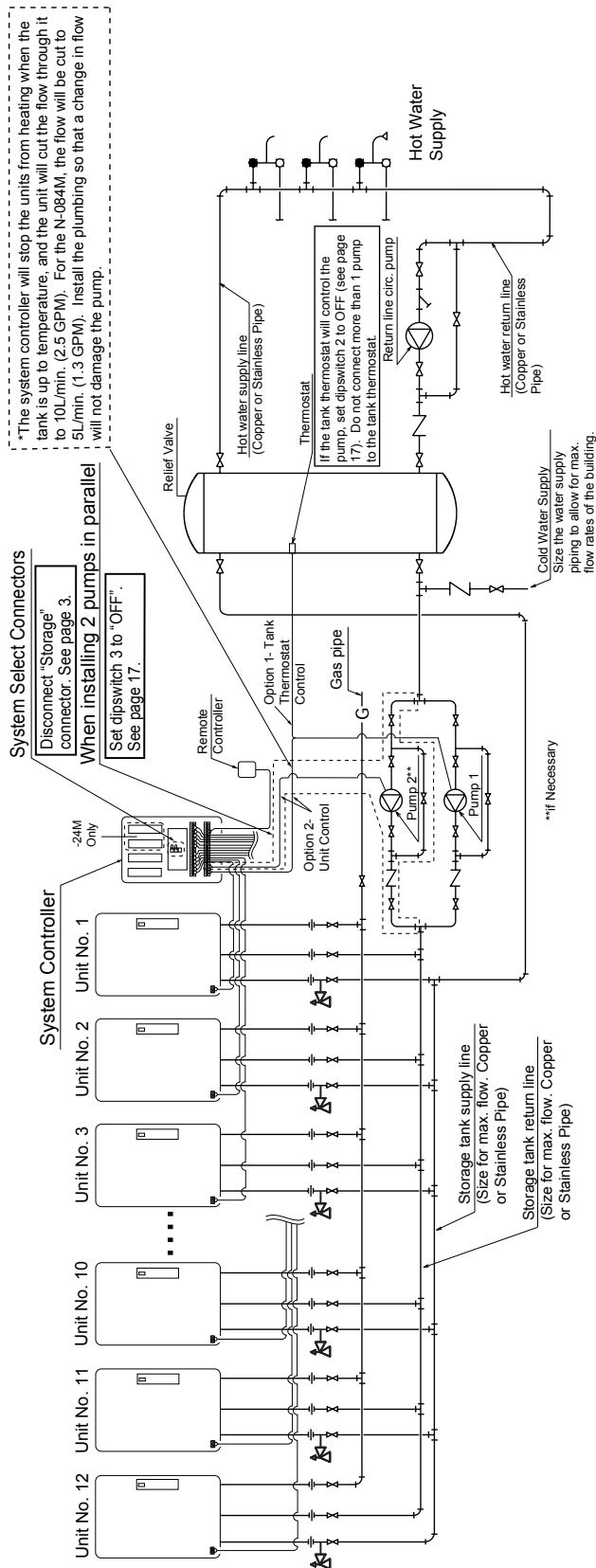

~ For the set temperature of the remote control, use the set temperature (of the thermostat) + about 6°C (10°F).

~ To achieve the highest recovery, size the storage tank circulation pump for maximum capacity.

N-132M, N-1321M-ASME, NC380-SV-ASME: 12 GPM (each) @ 50 ft. of head (160°F setting or less),

N-084M: 7.4 GPM (each) @ 40 ft. of head (160°F setting or less),

N-0931M, NC250: 9.0 GPM (each) @ 40 ft. of head (160°F setting or less),

N-0841MC, NCC199: 9.0 GPM (each) @ 40 ft. of head (160°F setting or less) + piping losses through the system.

Verify that the supply pressure to the units is at least 30 PSI.

2. Installation

Securing to the wall



Be sure to do

- The weight of the device will be applied to the wall. If the strength of the wall is not sufficient, reinforcement must be done to prevent the transfer of vibration.
- Do not drop or apply unnecessary force to the device when installing. Internal parts may be damaged and may become highly dangerous.
- Install the unit on a vertical wall and ensure that it is level.

Item	Check	Illustration
Locating Screw Holes	<div style="border: 2px solid black; padding: 5px; text-align: center;"> CAUTION </div> <ul style="list-style-type: none"> • When installing with bare hands, take caution to not inflict injury. • Be careful not to hit electrical wiring, gas, or water piping while drilling holes. <ol style="list-style-type: none"> 1. Drill a single screw hole, making sure to hit a stud. 2. Insert and tighten the screw and hang the unit by the upper wall mounting bracket. 3. Determine the positions for the remaining four screws (two for the top bracket and two for the bottom), and remove the unit. 	<p style="text-align: center;">Location of Screw Hole</p> <p style="text-align: center;">Locating Screw Holes</p>
Mounting	<ol style="list-style-type: none"> 4. Drill holes for the remaining four screws. Use wall anchors if necessary. 5. Hang the unit again by the first screw, and then insert and tighten the remaining four screws. 6. Take waterproofing measures so that water does not enter the building from screws mounting the device. 	<p style="text-align: center;">Tapping Screws</p> <p style="text-align: center;">Wall Anchors</p> <p style="text-align: center;">Tapping Screws</p>
Structure	<ul style="list-style-type: none"> • Make sure the unit is installed securely so that it will not fall or move due to vibrations or earthquakes. 	

3. Gas Piping

Follow the instructions from the gas supplier.

Gas Connection

- Gas flex lines are not recommended unless they are sized for the maximum input kW (Btu/h·MJ) of each unit.
- Do not use piping with a diameter smaller than the size of the gas inlet to each unit
- After installation, check the gas line for any leaks before using.

Gas Valve

Install a gas shutoff valve for every unit installed.

Gas Meter

Select a gas meter capable of supplying the entire kW (Btu/h·MJ) demand of all gas appliances that the meter serves. Size the gas line for the entire kW (Btu/h·MJ) demand also.

4. Water Piping

Ask a qualified plumber to perform the installation. Observe all applicable codes.

- The plumbing should be installed by a qualified plumbing contractor according to all applicable codes and regulations.
- Insulate or apply heating materials to the supply and hot water piping to prevent freezing during cold weather and to prevent heat loss through the piping.
- Use a union coupling or flexible pipe for connecting the units to ease service and maintenance.
- Refer to the system diagrams for supply and hot water pipe sizing. Do not install piping that is smaller than the inlet or outlet water connections on the units.
- If using an expansion tank, make sure it is correctly sized for the system.
- Use only copper or stainless steel pipe for all plumbing.
- Keep the plumbing as simple as possible.
- Avoid using pipes in which air can accumulate.
- * Use only approved materials, and have the installation inspected upon completion.

5. Electrical Wiring



Disconnect Power

Do not connect electrical power to the unit until all electrical wiring has been completed.

This appliance must be electrically grounded in accordance with local codes, or in the absence of local codes, with the National Electrical Code, ANSI/NFPA 70. In Canada, the latest CSA C22.1 Electrical Code.

Caution: Label all wires prior to disconnection when servicing controls. Wiring errors can cause improper and dangerous operation.

Verify proper operation after servicing.

The system controller is supplied with a pre-installed 3 prong electrical cord. Use an appropriate grounded electrical receptacle.



WARNING

Electrical Shock Hazard

Do not turn power on until electrical wiring is finished. Disconnect power before servicing.

Failure to do so may result in death or serious injury from electrical shock.

- The electrical supply required by the system controller is 120V AC at 60 Hz. Use an appropriate circuit.
- Do not disconnect the power supply when not in use. When the power is off, the freeze prevention in the water heater will not activate, resulting in possible freezing damage.
- Do not let the power cord contact the gas piping.

Tie the redundant power cord outside the system controller. Putting the redundant length of cord inside the system controller may cause electrical interference and faulty operation.

Ground

- To prevent electrical shock, always plug the system controller into a grounded electrical receptacle. Do not remove the ground prong from the electrical cord.



CAUTION

Electrostatic discharge can affect electronic components. Take precautions to prevent electrostatic discharges from personnel or hand tools during the system controller installation and servicing to protect product's electronic control.

6. Unit Wiring

Before making wiring connections from each unit to the system controller, make sure that the electrical power has been disconnected.

1. Remove the front cover from the system controller and each unit.

Note: If remote controller RC-7647M or RC-7650M (°C temperature display) is being used, an adjustment to all water heaters connected to the system controller will be necessary. Make this adjustment prior to making the electrical connections to the system controller. Refer to page 17 for instructions.

- Connecting the communication cable to Unit 1
2. Using the remote controller cord supplied with the water heater, insert the end with Y terminals through one of the openings in the base of the system controller. Connect the Y terminals to terminal block "01".
 3. Cut off the molex connector on the other end of the remote controller cord. Attach the Y terminals (supplied with the remote controller cord) in place of the molex connector.
 4. Pass the free end of the remote controller cord through the wiring thway of the water heater, and attach the Y terminals to the terminal block as shown below. Secure the remote controller cord to the water heater using a clamp.
- Connecting the communication cable to Units 2-12 and 13-24
5. Connect Units 2-12 and 13-24 (-24M only) in the same fashion as Unit 1. Be sure to connect the units to the system controller terminals in order (02, 03,.....,12). Failure to do so will result in a system fault.

Note:

- If a longer communication cable is needed, use 18 AWG wire to a maximum length of 45 feet.
- Unused water heater terminals in the system controller can be left as is.

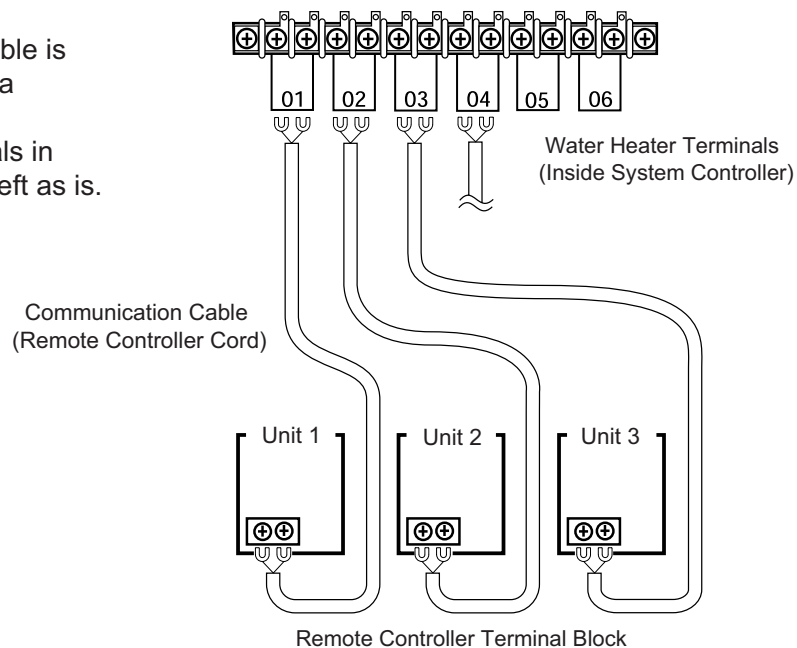
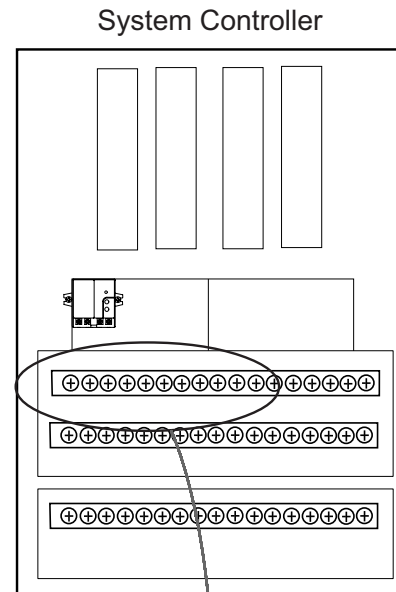

7. Connecting the Remote Controller

1. Pass the remote controller cord through one of the openings in the base of the system controller. Connect the Y terminals to the remote controller terminal block as shown below.
2. Install the remote controller as outlined in the water heater installation manual. If necessary, the remote controller cord can be extended up to 300' with 18 AWG wire.
3. Only 1 remote controller can be connected to the system controller. Do not connect the extra remote controllers to the water heaters.
4. If no additional connections are going to be made (pump, etc.), replace the front cover of the system controller.

Note: If remote controller RC-7647M or RC-7650M (°C temperature display) is being used, an adjustment to all water heaters connected to the system controller will be necessary. Make this adjustment prior to making the electrical connections to the system controller. Refer to page 17 for instructions.

Do not connect the communication cable from the units to the remote controller terminal block. A malfunction will occur.

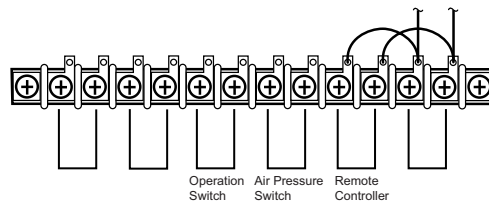
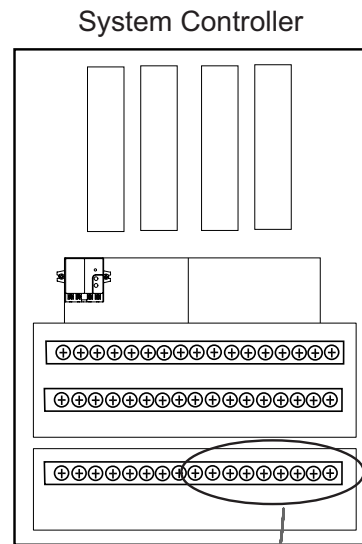

Remote Controller Terminal Block
(Inside System Controller)



Remote Controller
Cord

To Remote Controller

8. Optional Connections

Circulation Pump Terminals

- Use these terminals to control the pump in any circulating system.
Connected this way, the system controller will control the function of the pump.
- Use a normally open relay to supply power to the pump. Use a thermal relay if necessary.

(1) When operating with 1 circulation pump

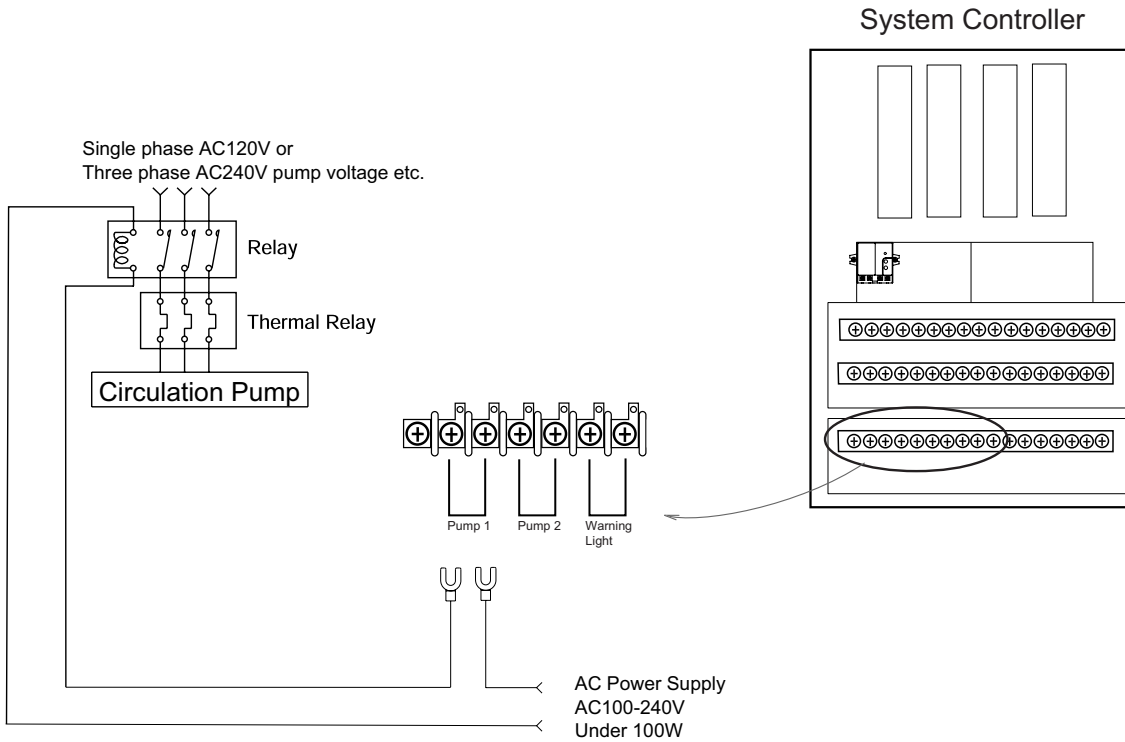

* If there is only one pump, connect to "Pump 1" terminals.

(2) If two circulating pumps will be used:

Connect as below if two circulating pumps will be used. The two pumps can be set to alternate with a dipswitch change.

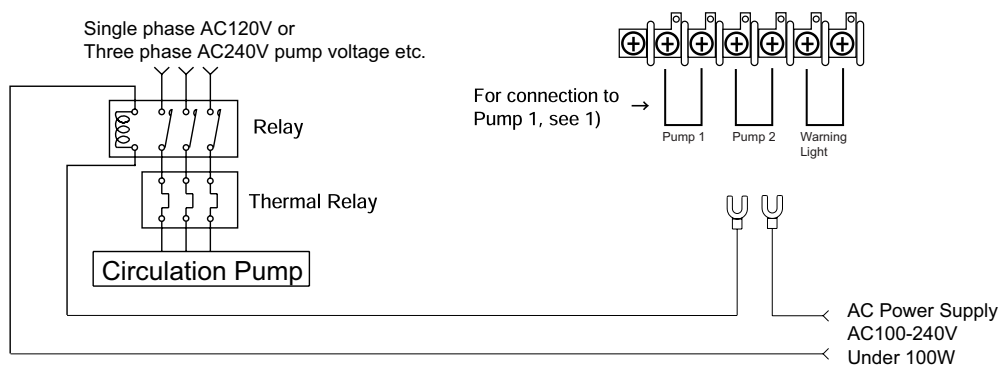

* Do not connect both Pump 1 and Pump 2 to the same terminal block.

* After connecting as shown above, set dipswitch 3 to "OFF" (See page 17).

• Piping diagram for parallel pipe installation

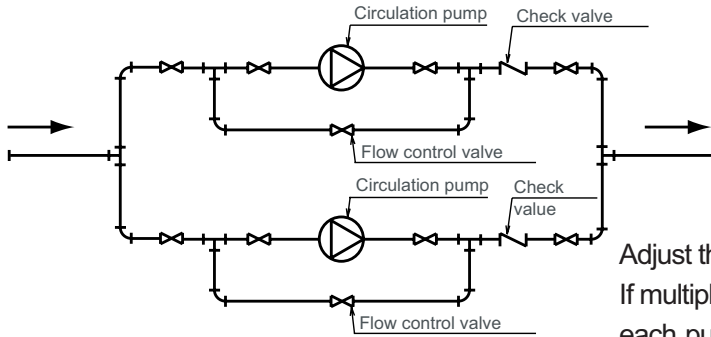

Adjust the pump flow with the flow control valves. If multiple pumps are used, control the flow of each pump with separate valves.

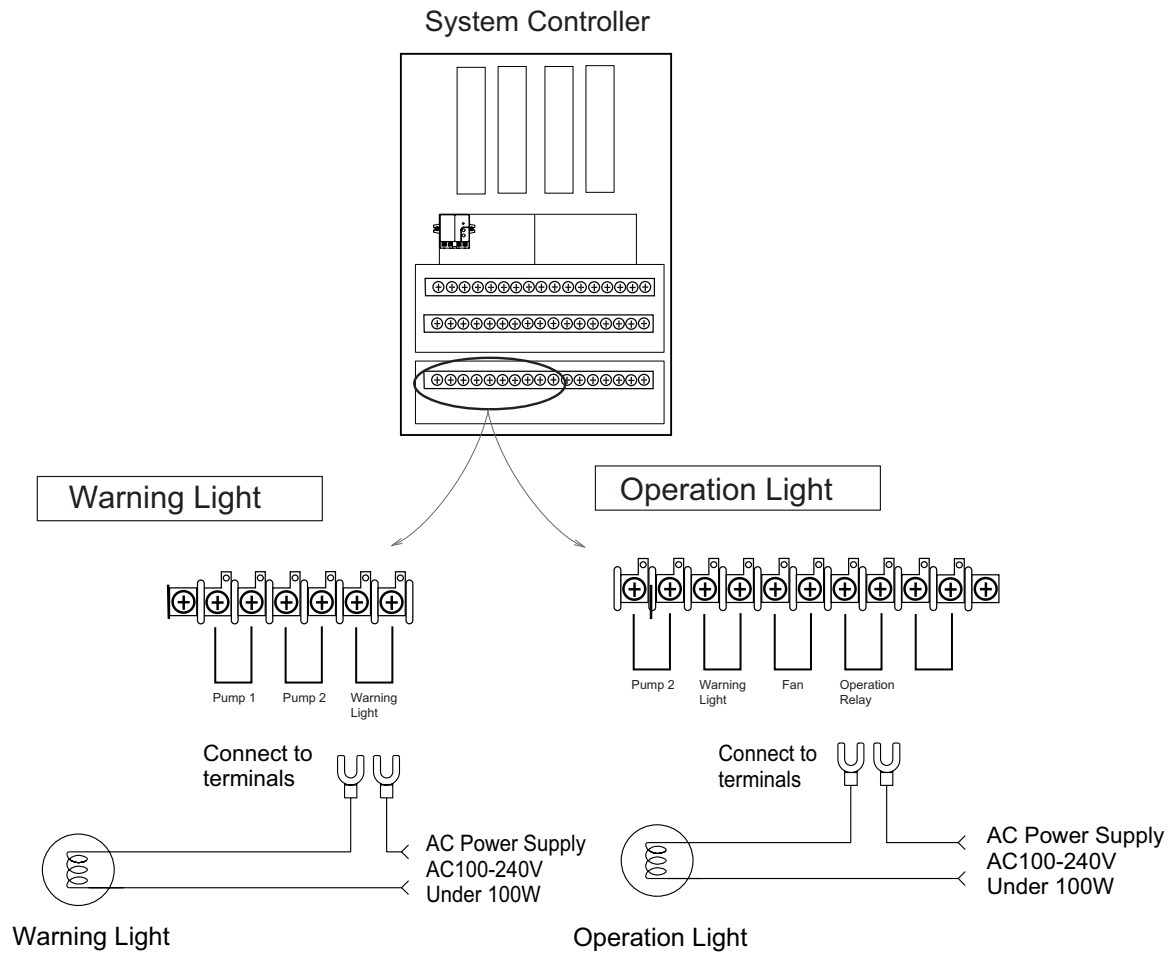

• A warning light can be connected to the system as above to warn of any abnormal operation. When this light flashes, check for an error code on the remote controller and diagnose accordingly.

• An operation light can be connected to the system controller as above in order to indicate when power has been turned on to the system.

Exhaust Fan Terminal

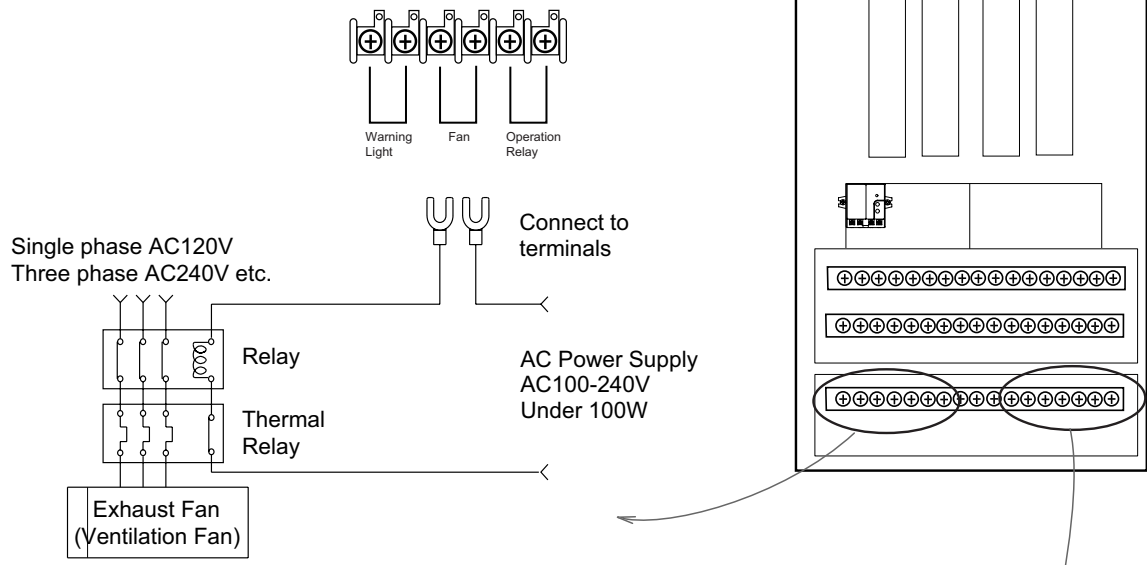

- These terminals will close when any of the units are heating or when the fan on any of the units is blowing. These terminals can be used to control an exhaust fan or damper in this way.
- Use a relay to provide power to the fan or damper. Use an additional thermal relay if necessary.

Pressure Switch/Safety Shutoff Switch Connection

Do not connect the communication cable from the water heater to these terminals.

- A pressure switch or other safety device can be installed to shut down the system under unsafe or improper operation.
 - Please use a low voltage (15V) junction, normally open relay.
 - This terminal is short circuited at time of shipment.
- In order to use this feature, disconnect the connector at the air pressure switch terminals as shown below.

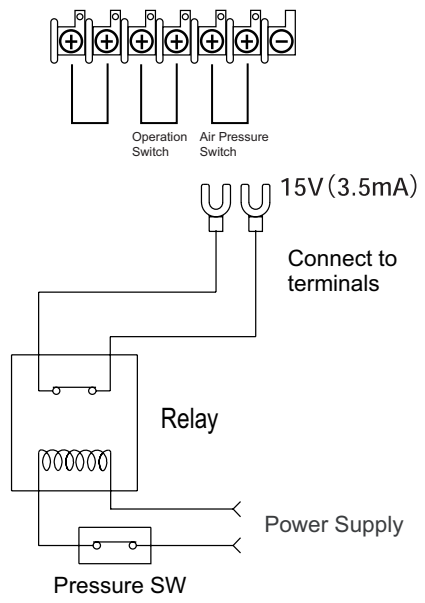
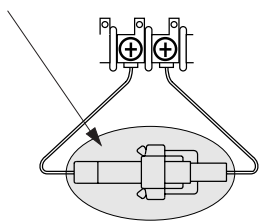

Connecting an External Operation Switch

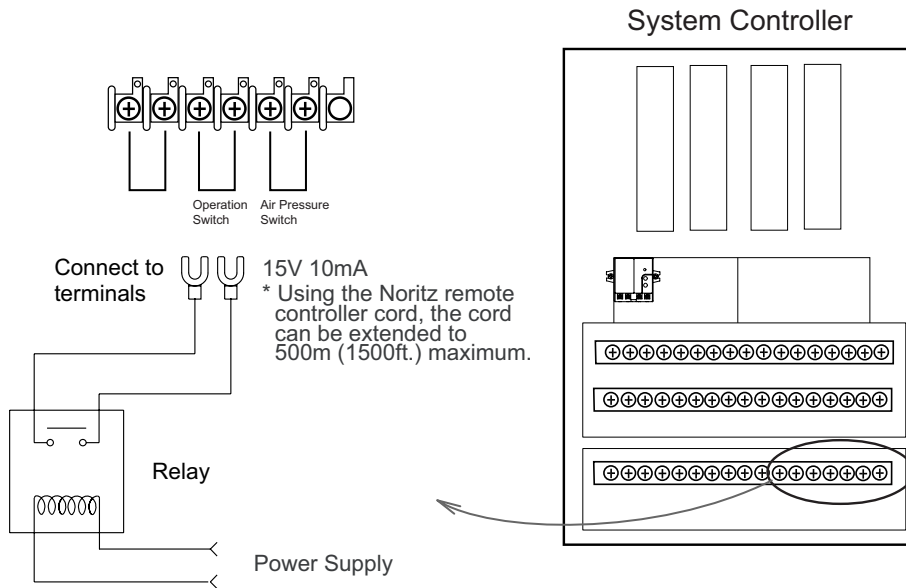

- Follow this procedure to use an external switch to turn power on and off to the unit instead of the remote controller.
 - (1) The power to the units will be on when the external switch is turned on (closed).
 - (2) The power to the units will be off when the external switch is turned off (open).
- Use a low voltage (15V) junction.
- * If the units are installed with a recirculation system, a storage tank or a filtration system, the pump will also turn on or off with this switch.







9. Trial Operation

The installer should test operate the system, explain to the customer how to use the units, and give the owner the Installation and Operation Manual before leaving the installation.

- (1) Connect electrical power to the system controller and each of the units.
 - (2) Open the gas shutoff valve, the main water valve, and the water shutoff valves on all of the units.
 - (3) Turn the power ON with the remote controller. (The Operation Lamp will light up.)
 - (4) Slowly open a hot water fixture and confirm that the units ignite in sequence and that the Burner On Lamp on the remote controller lights.
- If an "11" or "12" error code flashes on the remote controller, there may be air in the gas line. Hit the Power Button ON and OFF a few times and then open the fixture again to try igniting the unit again.
 - If this fixture does not cause all of the units to ignite, test the rest of the units by switching which is the primary unit by pressing either the Maximum or Minimum Manifold Pressure Set Button on the circuit board of the unit.
 - Operate all of the units and confirm that the water temperature corresponds to the temperature set on the remote controller. Set the remote to the lowest temperature to maximize water flow. If the water temperature is hotter than the set temperature, check to make sure that the remote is connected to the system controller, and that the system controller is connected to the other units.
 - If the units do not operate properly, refer to the Troubleshooting section of the Owner's Manual.
- * After the test operation, clean any debris off of the filter on the water inlet and replace the front cover on all water heaters. Replace the front cover of the system controller if not already done.

Checking Water Flow (Maintenance Monitors)

Necessary only for recirculation systems

- (1) Press the temperature up and down buttons  and  simultaneously for more than 2 seconds.
(The remote control will display the maintenance monitors.)
* "Unit No.", "Data No." and "Data" are displayed on the remote controller temperature display.
- (2) Press the "FLOW METER ALARM SET" button to change which unit's information is being displayed.
(The combustion lamp of the selected unit will flash twice.)
* When switching "Unit No.", the display will change from "5C → 01 → Data No." → "01 → 02 → Data No." → "02 → 03 → Data No." . . . "(Last Unit)No. → 5C → OFF" when the "FLOW METER ALARM SET" button is pressed.
If the "FLOW METER ALARM SET" button is not pushed to change the Unit No., the Data No. for that Unit will then be displayed on the remote controller.
- (3) Press the temperature up or down buttons  or  to select Data No.14. The water flow through that heater will be displayed.
- (4) Repeat (2) - (3) for all water heaters. Adjust so that the total water flow of all devices is 2 GPM or more.
- (5) Press the temperature up and down buttons  and  simultaneously for over 2 sec. to return to the temperature display.

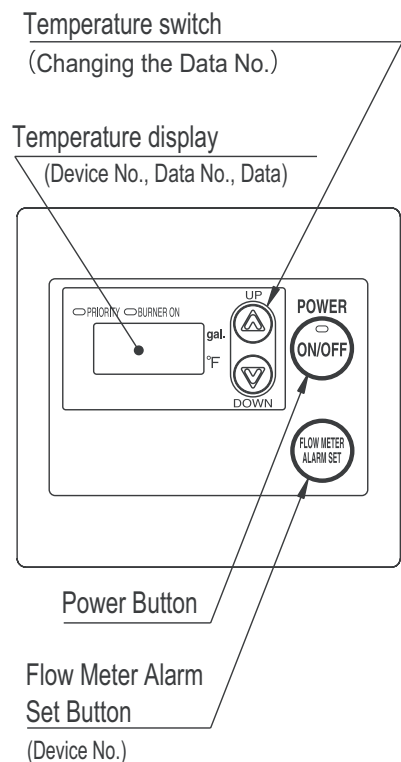

Dipswitch Settings

Disconnect the power to the system controller and each of the units before changing the dipswitches. Otherwise, settings will not take effect.

○ : ON ● : OFF

Dipswitch	SW1	SW2	SW3	SW4	SW5	SW6	SW7	SW8
		Pump abnormality detection	Pump rotation	125° F recovery during high-temperature setting				
		○ Yes	○ No	○ Set temperature				
		● No	● Yes	● 125° F				

* All dipswitches are set to ON from the factory.

SW2: Pump abnormality detection

Set to OFF if the pump will not be connected to the system controller, but instead the pump will be controlled by an external control device.

SW3: Pump rotation

Set to OFF if using 2 pumps.

SW4: If the switch is set to OFF, and the Power Button is turned OFF and ON, the unit will accept 125° F return water (if the unit is set at that temperature or higher).

When the dipswitch is ON, the unit will allow the standard return temperature.

* Do not change any other dipswitches.

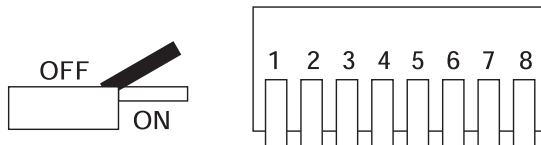

Water Heater Dipswitch Settings (When using remote controller RC-7647M or RC-7650M)

When using remote controller RC-7647M or RC-7650M (°C temperature display), a dipswitch change will be necessary on all water heaters connected to the system controller. Refer to the below instructions to make the adjustment. A remote controller will need to be connected to the water heater being adjusted.

- Connect electrical power to the water heater and wait 10 seconds before proceeding to step 2.
- Within the first ten minutes of connecting electrical power, before turning on the operation button, hit the [▲] or [▼] button on the remote controller and hold until the display blinks "99". If "99" does not blink on the remote controller, unplug the water heater and try again.
- Use the [▲] or [▼] button on the remote controller to scroll to the appropriate dipswitch number as indicated below.
- Press the "FLOW METER ALARM SET" button for 0.5 sec to change the setting ON/OFF:
ON: "priority" lamp flashes.
OFF: "priority" lamp goes off.
- For models N-084M(-DV)(-ASME), N-132M(-ASME), N-1321M-ASME, NC380-SV-ASME:
Change "A8" from OFF to ON. Do not adjust any other dipswitches!
For models N-0931M(-DV,-OD)-ASME, N-0841MC(-DV), NC250(-SV,-DV)-ASME, NCC199(-SV,-DV):
Change "2F" from OFF to ON. Do not adjust any other dipswitches!
- When the dipswitch has been adjusted, confirm the setting by pressing and holding both the [▲] and [▼] buttons on the remote controller until the controller emits a beeping noise. The new setting will be lost if this is not done.
- Repeat this entire procedure for every water heater that will be connected to the system controller.

10. Dimensions

