

# Model NC250 Series Commercial Water Heater Specification Sheet

Job Name \_\_\_\_\_  
 Location \_\_\_\_\_  
 Architect/Engineer \_\_\_\_\_  
 Wholesaler \_\_\_\_\_  
 Contractor \_\_\_\_\_  
 Model No. \_\_\_\_\_  
 Gas Type \_\_\_\_\_  
 No. of Units \_\_\_\_\_ Total BTU/hr Input \_\_\_\_\_  
 Flow Rate (GPH) \_\_\_\_\_  
 Notes \_\_\_\_\_

- **Standard Input** - gas consumption ranges from 11,000 BTU/h to 250,000 BTU/h
- **Compact Design** - ANSI Z21.10.3/CSA 4.3 certified design that can be wall-mounted indoors or installed outdoors (-SV model only) using optional Vent Cap
- **Durable Stainless Steel Casing**
- **Heat Exchanger** - manufactured with commercial grade copper, 25% thicker piping than standard models
- **Venting Options** - available in power or direct vent model that requires 4" Category III stainless steel pipe
- **Direct Electronic Ignition**
- **Multi-System Capability** - units can be linked together by using either the optional 2-unit Quick Connect or multi-unit System Controller for up to 24 units.
- **Fully Modulating** - BTU input can range from 11,000 to 6 million BTU/h (for 24-unit Multi-System) with stable combustion provided by the industry's 1st Dual-Flame Burner
- **Thermal Efficiency** - 84% efficient for use with natural gas or propane
- **Temperature Controls** - includes remote thermostat that can precisely adjust the output temperature from 100°F to 180°F
- **Safety Devices** - Flame Sensor, Overheat Prevention Device, Lightning Protection Device, Freeze Protection
- **Five Year Limited Heat Exchanger Warranty for Commercial Use**
- **Five Year Limited Parts Warranty**
- **ASME Certified** - all models are certified by ASME and the National Board



• **Approvals** - CSA, UPC, NSF, Low NOx Approved By SCAQMD (Rule 1146.2)



SV Model

DV Model

- Model**
- NC250 - \_\_\_\_\_ - ASME
- SV (Standard Vent)
- DV (Direct Vent)
- Accessories**
- Outdoor Vent Cap for -SV Model (#VC-4-1)
- Isolator Valves (#IK-WV-8)
- Pipe Cover (#PC-3S-SUS)
- Quick Connect Cord (#QC-1)
- System Controller
- 6-unit (#SC-201-6M)
- 12-unit (#SC-201-12M)
- 24-unit (#SC-201-24M)

## Dimensions

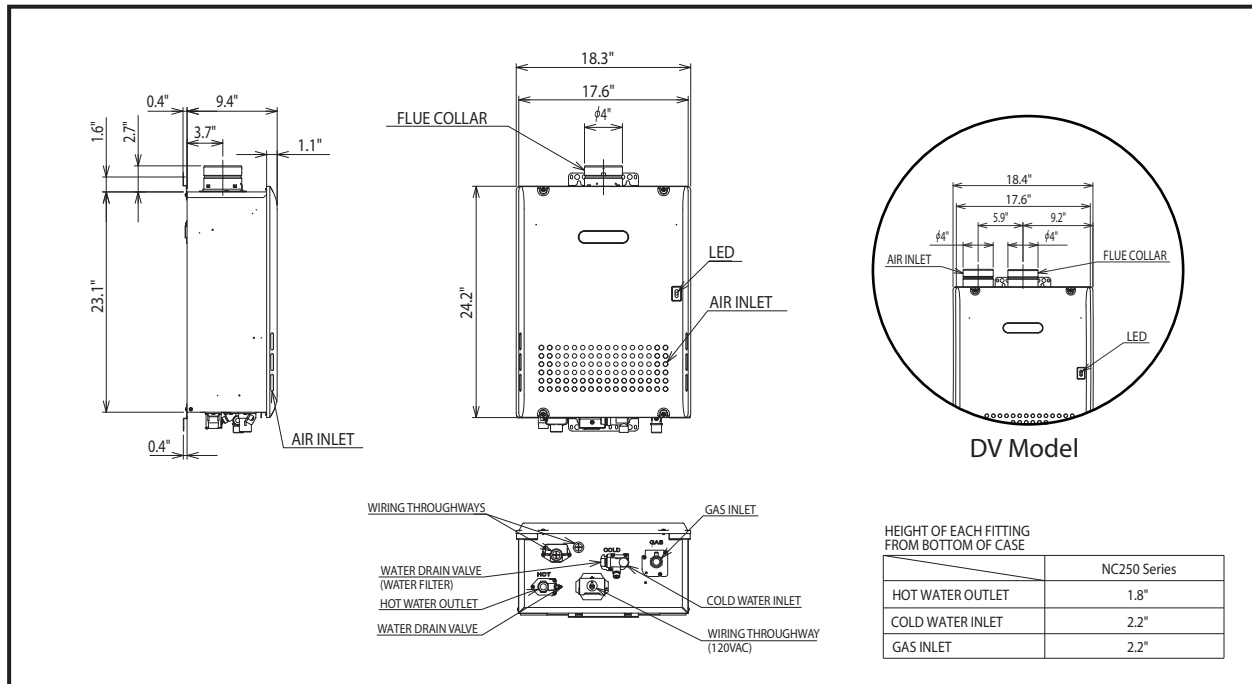

## Flow Rates

Temperature Rise (°F)		70	100
Flow Rate (GPM)	1-unit	6.0	4.2
	2-unit	12.0	8.4
	3-unit	18.0	12.6
	6-unit	36.0	25.2
	9-unit	54.0	37.8
	12-unit	72.0	50.4
	24-unit	144.0	100.8
Flow Rate (GPH)	1-unit	360	252
	2-unit	720	504
	3-unit	1080	756
	6-unit	2160	1512
	9-unit	3240	2268
	12-unit	4320	3024
	24-unit	8640	6048

## Pressure Loss

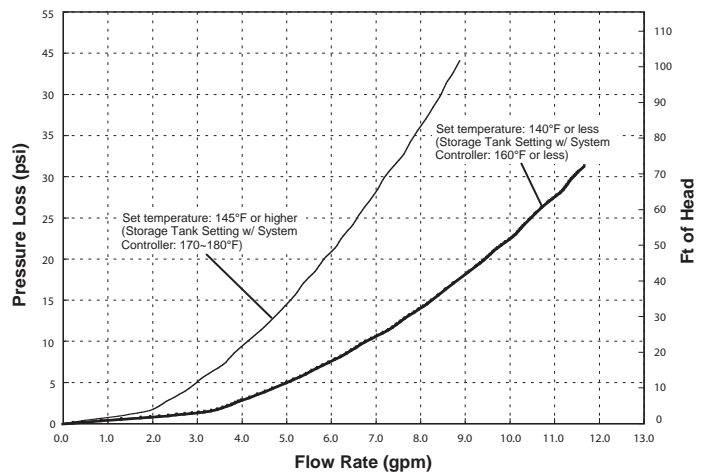

**NOTE:** For Quick-Connect and Multi-System installations, pressure loss remains constant throughout the system regardless of the number of units installed. Multiply the total number of units in the system by the required flow rate from each unit to determine the total pressure loss from the chart above.

## Power Supply and Consumption

Model Name	Supply	Consumption
NC250-SV-ASME	120VAC (60 Hz), less than 3 amps	NG: 64W Freeze LP: 77W Prevention: 145W
NC250-DV-ASME		NG: 85W Freeze LP: 100W Prevention: 161W

## Temperature Settings and Options

Temperature Settings	100-150°F (In 5°F intervals), 160, 170, *180°F (14 Options)
Default Temperature Options	120, 130, 140, *180°F (Default is 120°F)

\*181.4°F actual output temperature

## Specification

Commercial, gas-fired, wall-mounted water heater(s) shall be direct/power vent Model NC250 Series as manufactured by Noritz America Corporation. The water heater(s) shall have a 5-year limited Heat Exchanger warranty and a 5-year limited Parts warranty per Noritz Limited Warranty. Unit(s) shall be designed to burn natural/propane gas and certified by CSA International to the latest edition of ANSI standard Z21.10.3/CSA 4.3. Water heater(s) shall have a nominal flow rate capacity of \_\_\_\_\_ GPH @ 100°F rise with rated input of \_\_\_\_\_ BTU/hr. Water heater(s) shall be vented with 4" Category III stainless steel vent pipe at a distance not to exceed 15' (or equivalent) with 3 elbows for SV models and 45' (or equivalent) with 3 elbows for DV models terminating vertically or horizontally. Water heater(s) is rated for 150 PSI working water pressure and 300 PSI test pressure. Unit(s) shall have a stainless steel case, copper heat exchanger, stainless steel dual-flame burner, aluminum gas control valves, 3/4" inlet gas connection, and 3/4" brass inlet/outlet water connections. The power vent (-SV) and direct vent (-DV) models each weight 62 lbs. Unit(s) shall include features such as an adjustment for high elevation installations, temperature lockout, and 14 temperature options from 100-150°F in 5°F intervals and 160-180°F in 10°F intervals. The heater(s) shall be controlled by an internal circuit board that monitors the inlet and outlet temperatures with installed thermistors, sensing and controlling flow rate to set point temperature with air-fuel ratio controls in order to maintain thermal combustion efficiency. Unit(s) shall include safety features such as flame sensor system, thermal cut-off fuses, lightning protection device, overheat prevention device, freeze protection device, and fan rotator detector. Multi-system applications that require 2 units shall be installed by connecting the units using a single cable-only connection (Quick-Connect). Applications that require 3 to 24 units shall use a multi-unit central controller (System Controller). The water heater(s) exceeds the energy efficiency requirements of ASHRAE 90.1b-1992 and listed by SCAQMD rule 1146.2 Low NOx.

**Noritz America reserves the right to discontinue, or change at any time, the designs and/or specifications of its products without notice.**